

GENERAL

The Elevathor™ is a linear motor shifting a lens. This axis lens shifter allows changing working distance, field and spot size. The z-axis has a travel of 4 mm and a position accuracy of 65 nm. Combined with a rhothor™ deflection system this is a complete 3D deflection solution, allowing three dimensional laser tracking by controlling all axes simultaneously.

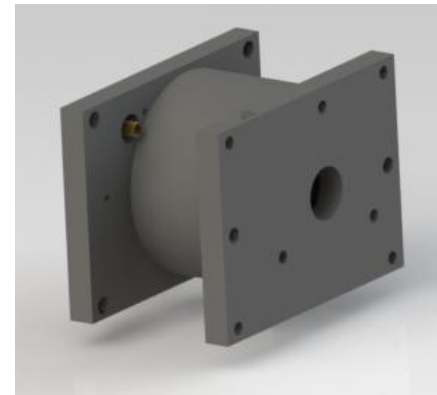

DIMENSIONS

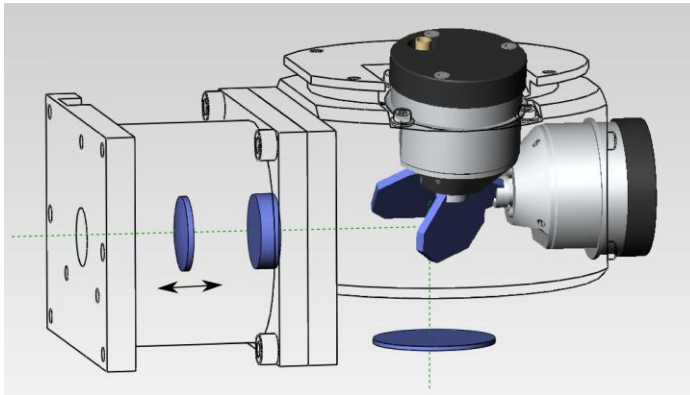
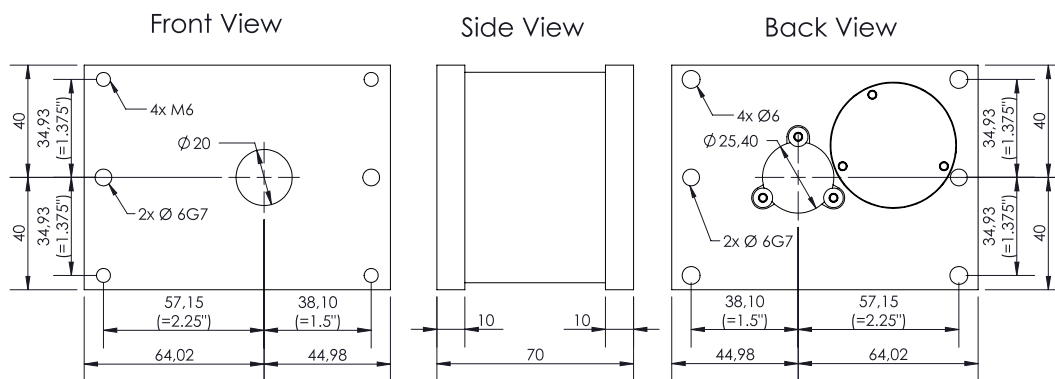
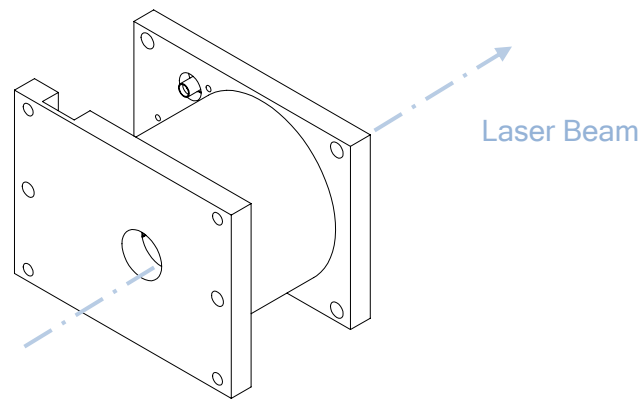

Dimensions in mm

GENERAL DATA

Elevathor™ digital interface

Principle:	moving coil
Regulator:	digital 18 bit
Amplifier:	class D
Position sensor:	optical

Mechanical data

Dimension:	109 x 70 x 80 mm
Weight:	0.8 kg
Travel Range:	4 mm
Velocity:	up to 0.4 m/sec
Bearing Type:	spring bearing
Step width:	about 65 nm
Cooling:	air cooled, no water cooling required
Free opening:	20 mm

Moving Lens

Diameter:	25 mm, 15 mm, 1 inch or 0.5 inch
Edge Thickness:	2-5 mm

Fixed Lens

Diameter:	25 mm or 1 inch
Edge Thickness:	2-5 mm

Typical Lens Setup

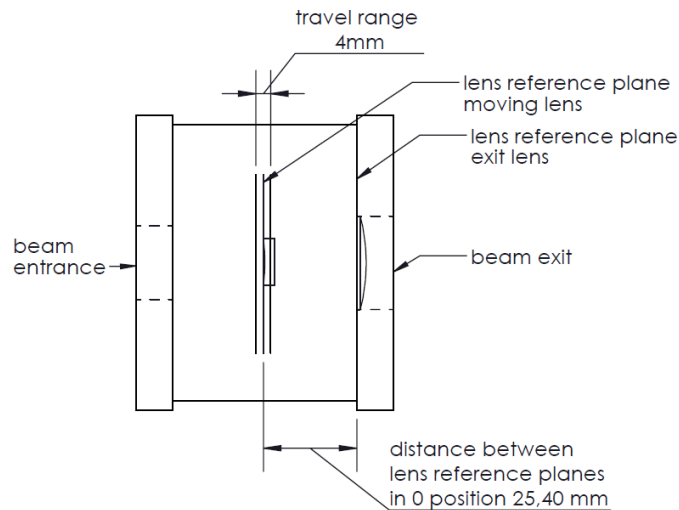

Connector

A SMA coax connector is used for connection between motor and CUA controller. The Elevathor™ z-axis uses the SDP (Shared Data Power) protocol.