

DATA SHEET
XY2-DC

XY2-100 ADAPTER BASE PLATE FOR RHOTHOR SMART DEFLECTORS™

NEWSON NV

Table of Contents

1	FEATURES	3
2	TYPICAL SETUPS	3
3	INTERNAL SCHEME.....	4
4	PIN ASSIGNMENT	4
4.1	XY2-100 INPUT : 25 PIN SUB-D SOCKET MALE/FEMALE.....	4
4.2	POWER CONNECTOR	4
5	XY2-100 STANDARD PROTOCOL INFORMATION.....	5
6	DIMENSIONS.....	5

1 FEATURES

- Baseplate for RTFE-XY2 front end IC
- Support for XY2-100 standard with 16-bit set points
- Channel X, Y and Z
- Standard 25 pin DSUB male and female connector
- Supports scanners generation 3 (RTA-ARXXX-3G)
- Power connection
- DIN rail clickable

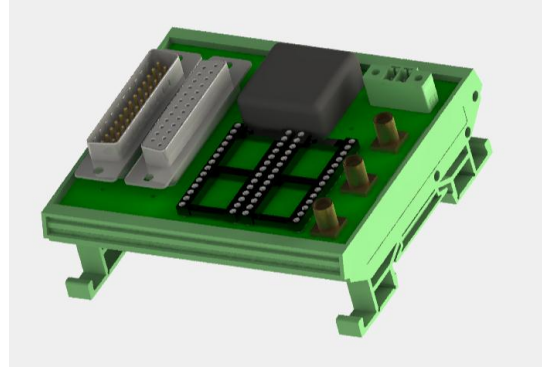

2 TYPICAL SETUPS

Connect a third party XY2-100 steering board with a 2D rhotor deflection system using the XY2-DC module equipped with a single RTFE-XY2 IC.

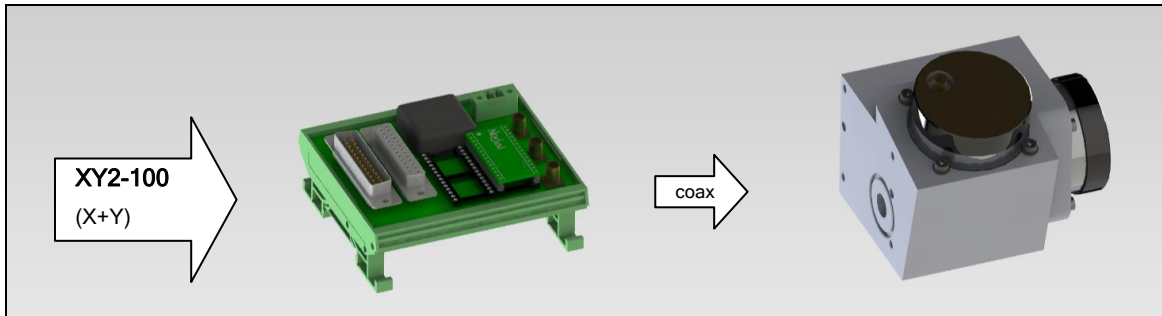

Connect a third party XY2-100 steering board with a 3D rhotor deflection system using a XY2-DC module. Both DIL sockets are then equipped with a RTFE-XY2 IC.

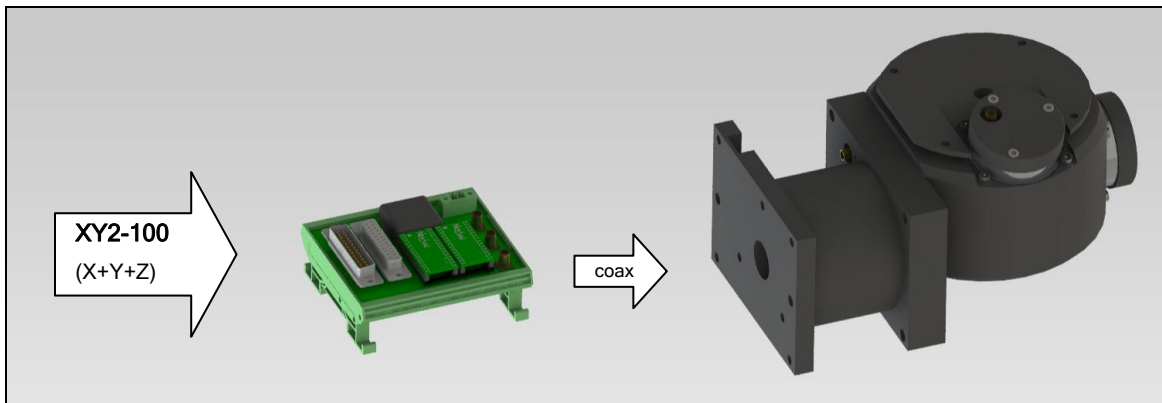

When the XY2-100 signal does not provide power to the scanner, power can be provided through the power connector. The power connector accepts 24 to 48 VDC.

3 INTERNAL SCHEME

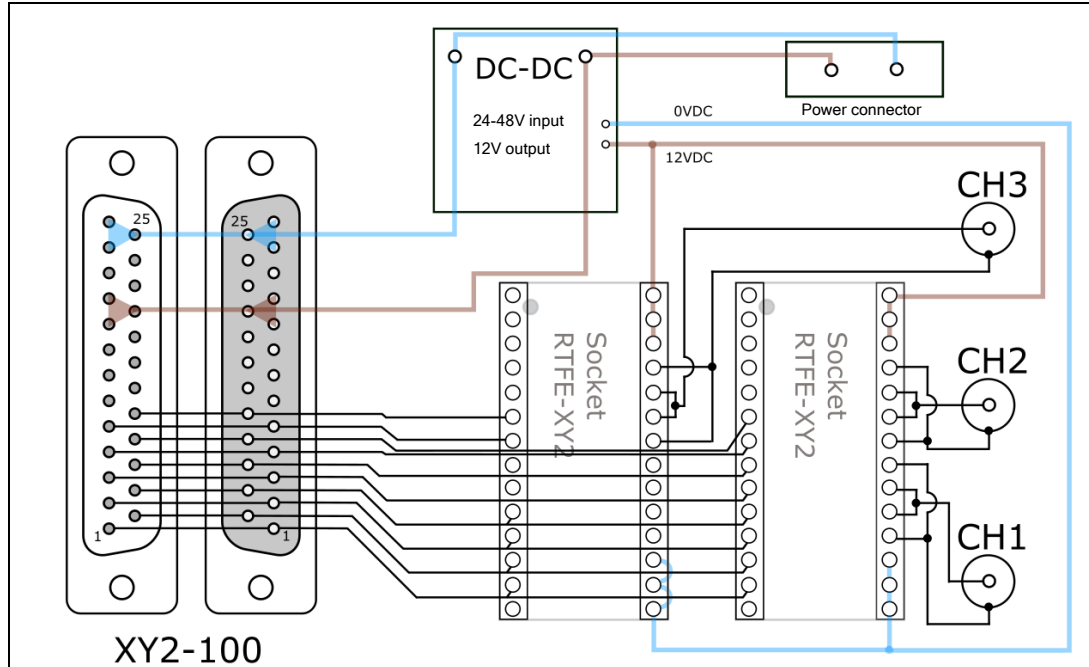

4 PIN ASSIGNMENT

4.1 XY2-100 INPUT : 25 PIN SUB-D SOCKET MALE/FEMALE

Pin No.	Name	Description
1 / 14	IO1- / IO1+	SENDCK: Continuously running clock
2 / 15	IO2- / IO2+	SYNC: Synchronises data transfer
3 / 16	IO3- / IO3+	CHANNEL1: Data to Channel1
4 / 17	IO4- / IO4+	CHANNEL2: Data to Channel2
5 / 18	IO5- / IO5+	CHANNEL3: Data to Channel3
9,10,22	PWS+	Scanner power supply input
11,23,24	PWS0	Scanner power supply input
12,13,25	PWS-	Scanner power supply input

4.2 POWER CONNECTOR

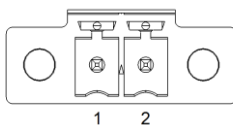

Connector Type: Phoenix MC 1,5/2-STF-3,81

Connect only when XY2-100 input cable does not provide scanner power supply input

Pin No.	Name	Description
1	DC+	DC input : 24-48VDC
2	DC0	DC input : 0V

5 XY2-100 STANDARD PROTOCOL INFORMATION

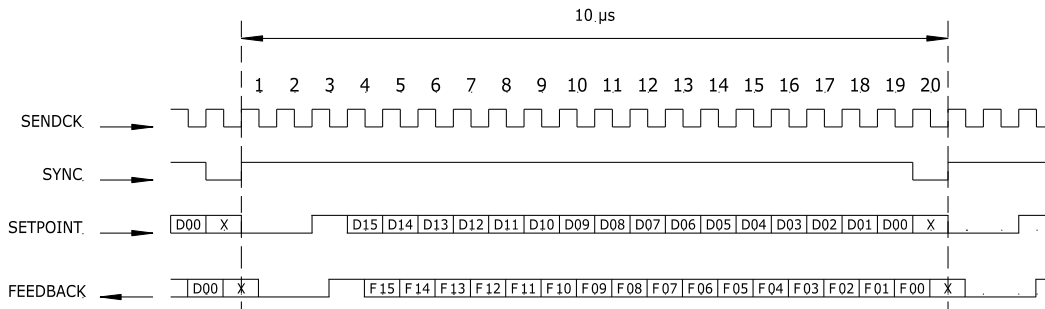

[D15-D00]: Set point, offset binary
 [F15-F00]: Actual position, offset binary
 [X]: DC

6 DIMENSIONS

